

stonetc...

THE
STONE
FOUNDATION
NEWSLETTER

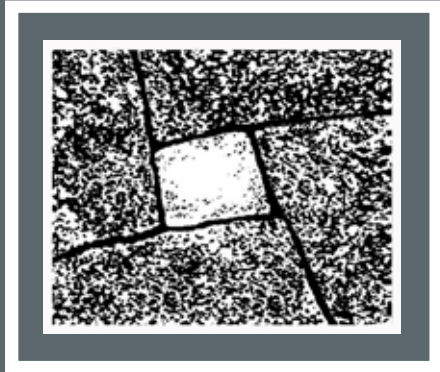

JULY, 2024

THE PERIODICAL GATHERING OF THE STONE 'TRIBE'

STONEWORK SYMPOSIUM 2024

AT THE VERMONT GRANITE MUSEUM
BARRE, VERMONT SEPTEMBER 24-28

1908 SEPTEMBER 1908						
Sun.	Mon.	Tue.	Wed.	Thu.	Fri.	Sat.
1	2	3	4	5	6	7
8	9	10	11	12	13	14
15	16	17	18	19	20	21
22	23	24	25	26	27	28
29	30	31				



2024 SEPTEMBER 2024						
Sun.	Mon.	Tue.	Wed.	Thu.	Fri.	Sat.
1	2	3	4	5	6	7
8	9	10	11	12	13	14
15	16	17	18	19	20	21
22	23	24	25	26	27	28
29	30	31				



STONEMWORK SYMPOSIUM 2024

September 24-28, Barre, Vermont

Host: The Vermont Granite Museum Fiscal Sponsor: The Stone Trust

PROVISIONAL SCHEDULE

Please note that Wednesday, Thursday, and Friday mornings are unscheduled. Participants are at liberty to do as they please.

1) Watch the **DEMONSTRATIONS** at the VGM.

2) Go on the **TOURS** described in the column to the left,

3) Hike or Bike the **TRAILS** in the Barre Town Forest,

4) Help to **REBUILD** the dry stone fire circle done during the Dry Stone Walling Competition at STONEMWORK SYMPOSIUM 2008. (Or Watch this happen.) This is an opportunity for **Stone Foundation, Stone Trust** and **Dry Stone Canada** walling folks to work together. If this appeals to you, bring hand tools, put a few stones in place.

MONDAY and TUESDAY, September 23 — 24, Lettering Workshop
9:00 AM — 5:00 At the Vermont Granite Museum (VGM)

TUESDAY, September 24

5:00 PM — 10:00 PM. . .At the Vermont Granite Museum (VGM)
SYMPOSIUM REGISTRATION and the **ROCKNOCKERS RENDEZ-VOUS**, a Social Occasion with food and beer available.

WEDNESDAY, September 25. . . Various locales and VGM

9:00 AM — 12:00. . .**DEMONSTRATIONS, TOURS, WALLING**
(and Late Registration)

NOON — 1:00. . .LUNCH
1:00 — 5:00. . .**PRESENTATIONS**
5:00 — 7:00. . .DINNER
7:30 — 10 . . . **PRESENTATIONS**

THURSDAY, September 26. . . Various locales and VGM

9:00 AM — 12:00. . .**DEMONSTRATIONS, TOURS, WALLING**

NOON — 1:00. . .LUNCH
1:00 — 5:00. . .**PRESENTATIONS**
5:00 — 7:00. . .DINNER
7:30 — 10 . . . **PRESENTATIONS**

FRIDAY, September 26. . . Various locales and VGM

9:00 AM — 12:00. . .**DEMONSTRATIONS, TOURS, WALLING**

NOON — 1:00. . .LUNCH
1:00 — 5:00. . .**PRESENTATIONS**
5:00 — 7:00. . .DINNER
7:30 — 10 . . . **GENERAL MEMBERSHIP MEETING**

SATURDAY September 26. . .VGM

10:00 AM — ? **THE ANNUAL BARRE GRANITE FESTIVAL**. . .VGM
Exhibits, Demonstrations, Music, Food and Fun.

The LITHIC OLYMPICS. . .The first manifestation of the Lithic Olympics was at STONEMWORK SYMPOSIUM 2008 in Barre. It has since been a popular SYMPOSIUM feature with contests such as LITHOBOLOS (stone ball bocce), the WHEELBARROW STEEPLECHASE, STONE-STACKING, the SHOT-PUT and others.

7:00 PM. . . **COMMUNAL DINNER**. . .VGM
and an **AUCTION** of items produced during the demonstrations.

DEMONSTRATIONS

will be happening at the Vermont Granite Museum (VGM).

Demonstration: JAPANESE GRANITE SPLITTING PROJECT
by Jesse Salisbury and Kazumi Hoshino.

Demonstrations: STONE-LETTERING and BAS-RELIEF CARVING
in slate and granite by Karin Sprague and Rob Gil.

Demonstration: GRANITE STONE CARVING, by a local artist.

TOURS

TROW AND HOLDEN

Makers of fine stonemworking tools for more than 100 years.

9:00 AM—Thursday and Friday.

45 South Main Street, in Barre, Vermont. Take a guided tour through the T&H factory and watch tools being made.

ROCK OF AGES QUARRY TOUR

9:00 AM—Wednesday Thursday and Friday

Meet at the visitor center to watch video of the quarry process. Guided tour will begin at 9:30 which includes views of the 600 foot deep quarry site and the 160,000 square-foot factory where stone cutting and carving can be observed from an observation deck. Price (paid to quarry): \$6.50.

HOPE CEMETERY in BARRE is well worth a visit for an (unguided) tour (as is Green Mount Cemetery in Montpelier).

HIKING/BIKING

There are trails through in the Barre Town Forest that pass through several abandoned and overgrown quarries. <https://www.hikingproject.com/trail/7028951/grand-lookout-out-and-back>.

MEALS:

Wednesday through Friday, LUNCH will be provided. Participants will make their own breakfast and dinner arrangements

On Saturday night there will be a COMMUNAL DINNER at the VGM and those who wish to participate will be asked to make a donation when they register,

LODGING:

Be warned, lodging in Barre is little steep and it fills up fast because the fall 'leafpeeping' season is near. It may be necessary to stay outside Barre. Symposium Participants are encouraged to make reservations early on—NOW is not too soon to do that!

CAMPING:

There are private and state park camping sites in the area.

An excellent private campground is located just outside Barre: <https://millstonehill.com/types/campsite/>

Also the VGM is allowing a limited number of tents to be placed without charge on land adjacent to the Museum. Portapotties will be available. For those without tents we found a place in Massachusetts that sells inexpensive one or two person tents—with free delivery to Barre!
<https://www.hiltonstentcity.com/collections/tents>

WORKSHOPS: The only workshops scheduled are two stone letter-carving workshops in slate and granite led by Karin Sprague and Rob Gil at the VGM on Monday and Tuesday, September 23-24.

PRESENTATIONS:

There will be a few 'Long-Form' presentations by notable speakers.

BUT THE PRINCIPAL PRESENTERS WILL BE YOU,

THE SYMPOSIUM PARTICIPANTS

The emphasis will be on a series of Short-Form/Show-and-Tell Presentations by Symposium Participants.

These will be in the *Pecha Kucha* style, wherein presenters show 20 or less images of STONE WORK and STONE ART—that you've done or that you photographed on your travels. Each image will be shown for 20 seconds as you comment on the material. There will be a very brief Q & A period.

This is an opportunity to show—and to see—examples of each other's work. Each Symposium participant is invited to show, and comment upon, many as 20 images, or as few as 6.

Portions of the programs of previous Symposiums have included such presentations, the ones in 2018 in Ventura California were especially interesting and well organized. BUT, in Santa Fe in 2022 time was lost because many people showed up at the last minute with their photos on flash-drives or phones, and the schedule was improvised and disordered. **Therefore. . .**

All those who wish to participate are encouraged to:

- 1) Inform tomas@stonefoundation.org of your intention **ASAP**
- 2) **And, by September 1st, supply him with the images** you will display. (wettransfer.com is recommended; it's effective and free. Or send a flash drive with your images to Tomas Lipps, 116 Lovato Lane, Santa Fe New Mexico, NM 87505
- 3) Take care in preparing your comments on the individual images you will show and practice your presentation, rehearsing your comments so each can be expressed within the 20 second

A Few Invited PRESENTERS:

ROBERT THORSON, geologist, scholar, teacher, author and enthusiastic expert in the subject of the dry stone walls of New England. <https://www.aacu.org/podcasts/academicminute/2024-02-robert-thorson-university-of-connecticut-stone-wall-science>

AKIRA INMAN, Canadian dry stone waller who trained as a banker stonemason in London, England and is now employed as a stone carver at Stravangar Cathedral in Norway.

DAVID F. WILSON, Scottish stone artist noted for his creative and skillful stonework in the public realm. David will be the organizer-in-chief of Stonework Symposium 2025 in Dundee, Scotland. <http://davidwilsonpublicartist.com/projects2/>

TERUKI KAMIYA Notable Japanese dry stone waller, artist, designer and founder of the Dry Stone Walling Association of Japan. <https://www.facebook.com/teruki.kamiya/>

JARED FLYNN, Certified Master Level Member of the Dry Stone Walling Association of Great Britain, Founding Member of The Stone Trust and its president from 2010-2014. Jared is known for his remarkable creative dry stone installations.

And OTHERS



The statue pictured above, *The Sculptor*, honors the immigrant Italian artisans who came to Barre in the late 19th and early 20th centuries. The monument, designed by Elmo Peduzzi was carved from a 30 ton block of Barre granite by Philip Paini from a model crafted by sculptor Giuliano Cecchinelli.

It is dedicated to one carver in particular, Milanese sculptor Carlo Abate, who came from Italy to Barre in 1896 and established the first art school in which students could learn drawing, design and other skills associated with the granite industry.

He also established a legacy, personified by the skilled artisans who emerged from the school that made Barre a well respected center of monumental carving in the USA. One imagines that Abate would approve of this artfully carved iconic figure that personifies the dignity of the artisan.

photo: Tomas Lipps

2000

2001 • 2003 • 2004 • 2005 • 2006 • 2007 • 2008 • 2010

2011 • 2012 • 2013 • 2014 • 2016 • 2017 • 2018 • 2022

2024

Each of the numbers in the list above represents a convivial gathering of individuals who share an affinity for stone and for what men, and women, create with it. Memorable occasions, all of them.

Stonework Symposium 2024 will be the 18th periodical gathering of our 'Stone Tribe.' I am proud to have organized 15 Symposiums and assisted with two others. Folks who participated in those events went home inspired.

This year's gathering is probably the last one for which I and my partner Mimi will be responsible, our last hoorah. (*Don't worry though, I will continue to edit and publish STONEXUS Magazine and the digital STONEZINE*).

We hope to see members in Barre who have been to previous Symposiums—as well as those who haven't yet made it to one. Please come, participate and enjoy the company of kindred spirits.

The Stone Foundation's path forward—how its future form and function will develop—will be discussed during an important general membership meeting at this year's event. If this matters to you, be there.

We hope to see you in September, in Barre.

Tomas

Tomas Lipps, Stone Foundation Founder & Fearless Figurehead

below: Mimi Lipps at Stonework Symposium 2008 in Barre.

right: That's me, also in Barre in 2008. I may look drunk, but I'm just happy. After months of planning, organizing, promoting and several days overseeing what was a very successful Symposium, I was glad to get my hands on some stones and work on the first Wheelbarrow Steeplechase course.



THE STONE FOUNDATION & STONEXUS PRODUCTIONS PRESENT
STONEMASONRY SYMPOSIUM 2024
BARRE, VERMONT SEPTEMBER 24-28

PRE-REGISTRATION FORM

SYMPOSIUM HOST; THE VERMONT GRANITE MUSEUM FISCAL SPONSOR: THE STONE TRUST

Name _____ Occupation _____

Company name, if any _____

Address _____

Phone(s) _____ Email _____

INVOLVEMENT WITH STONE

(Check all that apply)

<input type="checkbox"/> Stonemason	<input type="checkbox"/> Architect	<input type="checkbox"/> Sculptor	<input type="checkbox"/> Engineer
<input type="checkbox"/> Dry Stone Waller	<input type="checkbox"/> Landscape Architect	<input type="checkbox"/> Supplier	<input type="checkbox"/> Instructor
<input type="checkbox"/> Restoration Mason	<input type="checkbox"/> Landscape Designer	<input type="checkbox"/> Historian	<input type="checkbox"/> Hobbyist
<input type="checkbox"/> Novice Mason	<input type="checkbox"/> Sculptor	<input type="checkbox"/> Scholar	<input type="checkbox"/> Aficionado
<input type="checkbox"/> Contractor	<input type="checkbox"/> Letter Artist	<input type="checkbox"/> Quarrier	
	<input type="checkbox"/> Carver	<input type="checkbox"/> Geologist	Other _____

SYMPOSIUM REGISTRATION FEES

- _____ \$460: NON-MEMBERS:
- _____ \$360: MEMBERS: (unchanged since 2000). Also for members of THE STONE TRUST and DRY STONE CANADA..
To become a Stone Foundation member: <https://www.stonefoundation.org/> (PayPal payments & wire transfers accepted)
- _____ \$000: MEMBERS from OVERSEAS and MEXICO Fee WAIVED (\$60 payment requested for lunches, etc.)
- _____ SPOUSES of SYMPOSIUM PARTICIPANTS: Fee: WAIVED. (\$60 payment for lunches, etc.)
- _____ A discount on the registration fee will be available for any member who would otherwise be unable to attend.
Email tomas@stonefoundation.org
- _____ SINGLE DAY REGISTRATION FEE (for local folks): \$100 (Specify which day or days.)
- _____ SYMPOSIUM SPONSORSHIP: We ask those who can afford to do so to make a donation in any amount.
THE STONE FOUNDATION is not a 501C3 Non-Profit organization, but THE STONE TRUST is and donations to STONEMASONRY SYMPOSIUM 2024 and the STONE FOUNDATION through The STONE TRUST are tax-deductible.
Contact tomas@stonefoundation.org for information about this..

WORKSHOP REGISTRATION FEES

- _____ STONE LETTER CARVING WORKSHOP (slate, marble and granite): September 23-24. . . \$300
Registration limited to 12 persons. Instructors: Karin Sprague and Rob Gil <https://www.facebook.com/KarinSpragueStoneCarvers/>

\$ _____ TOTAL PAYMENT

We prefer that REGISTRATION FEES are paid, not through PayPal, but by check (USA) or money order sent to the Stone Foundation, 116 Lovato Lane, Santa Fe, NM 87505. . . or with cash or check on September 24th.
If you choose to pay upon arrival on the 24th, please let us know in advance that you intend to come. tomas@stonefoundation.org

- _____ Check here if you wish to participate in the LITHIC OLYMPIC events.
- _____ Check here if you wish to participate in the SHORT-FORM, SHOW AND TELL presentations.

Note: Short-form, show and tell presentations, aka *Percha Kucha*, are a format popular with architects. Participants display 20 images of stonework, commenting on each as it is shown— for 20 seconds. This is an opportunity for members to show and tell about their work—to receive feed-back about it. And it is an opportunity to see the work of others and hear them talk about it. This has been a feature of the past several Symposiums but this time it will comprise the majority of the program.

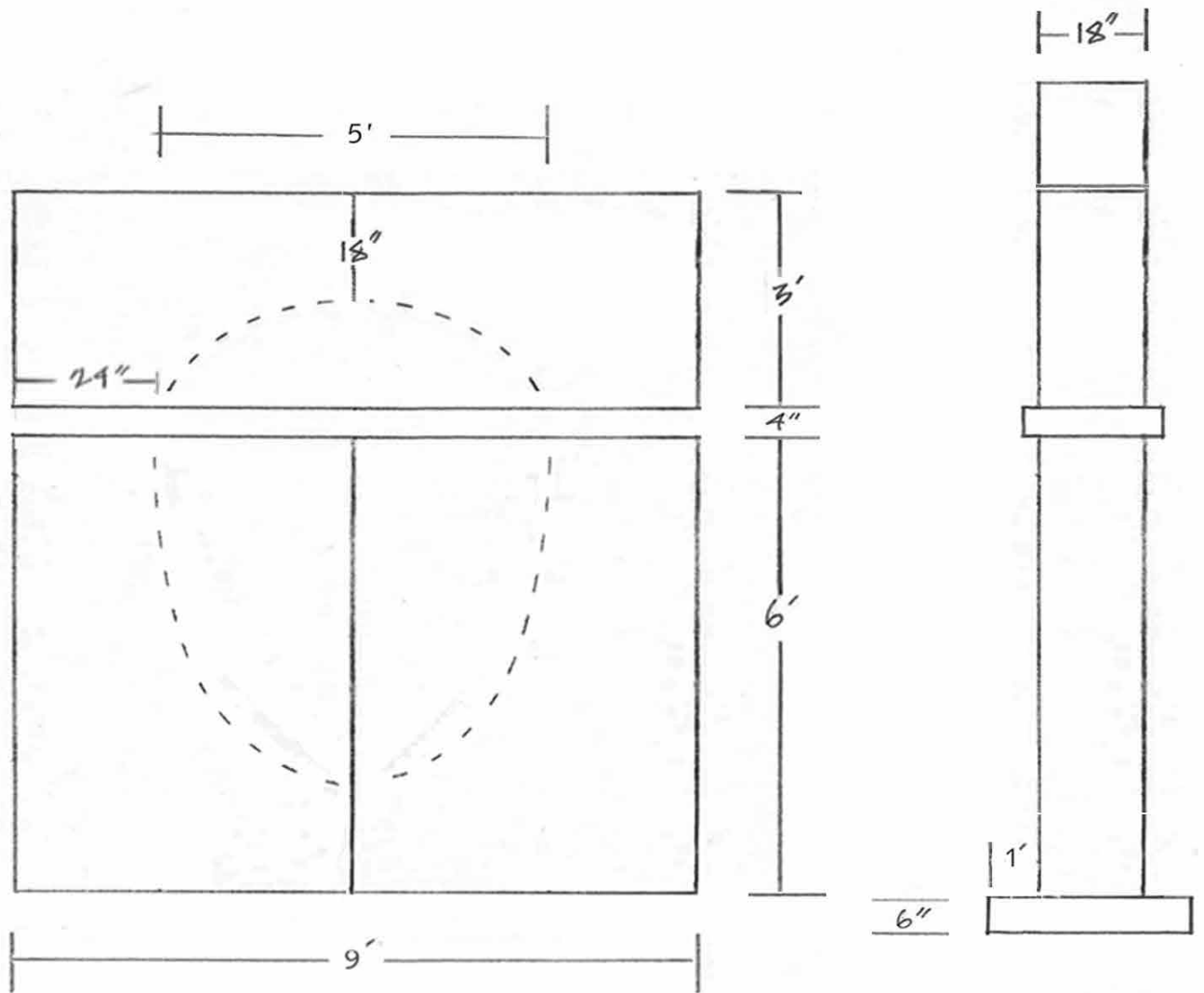

GRANITE PORTAL PROJECT
STONEMASONRY SYMPOSIUM 2024
 A demonstration of the Japanese technique of splitting granite by Jesse Salisbury and Kazumi Hoshino.

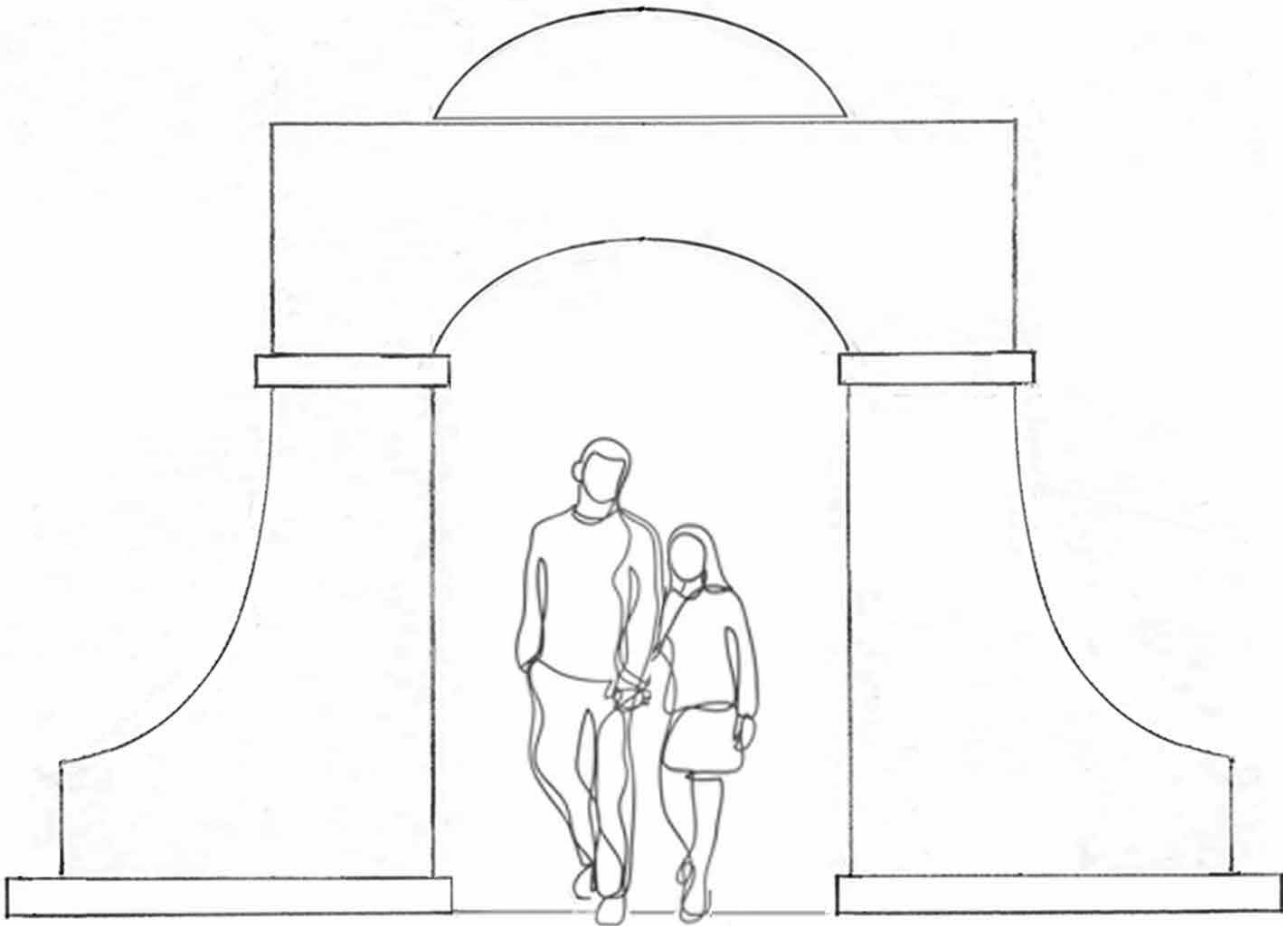

T L

The portal will be auctioned off during the communal dinner on Saturday night, as will the work of the other demonstrators—the poems carved in slate and granite by Karin Sprague and Rob Gil, and the granite carving by a local artist. Portal design by Tomas Lipps.